



LEGEND Series

LEGEND SERIES

Legend



500*1000

Legend mini



500*500

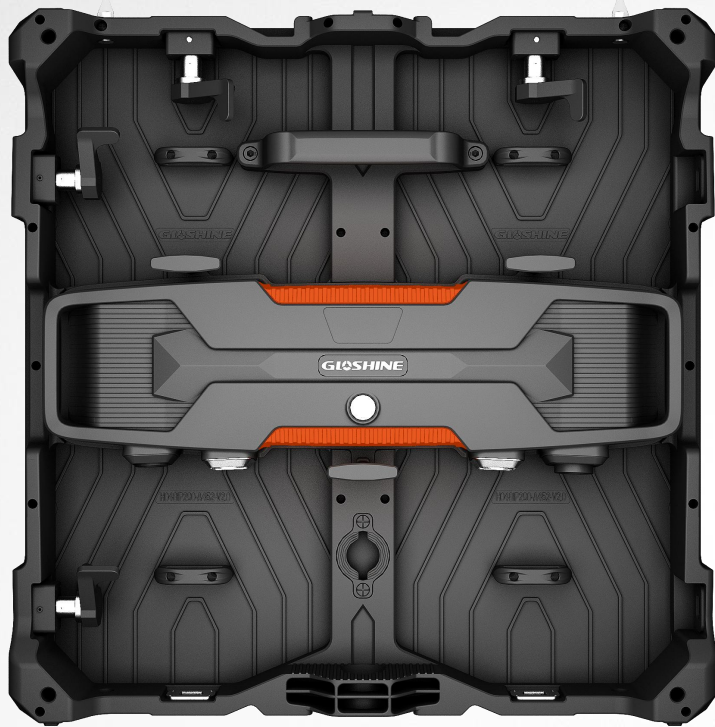

Legend

Pixel Pitch : 3.91mm

LED : SMD1921

Pixel Density : 65536pixel/m²

Brightness: 4000-5000nits

Refresh Rate : 1920Hz/3840Hz

Protection Level : Front IP65,Rear IP54

Usage :Outdoor

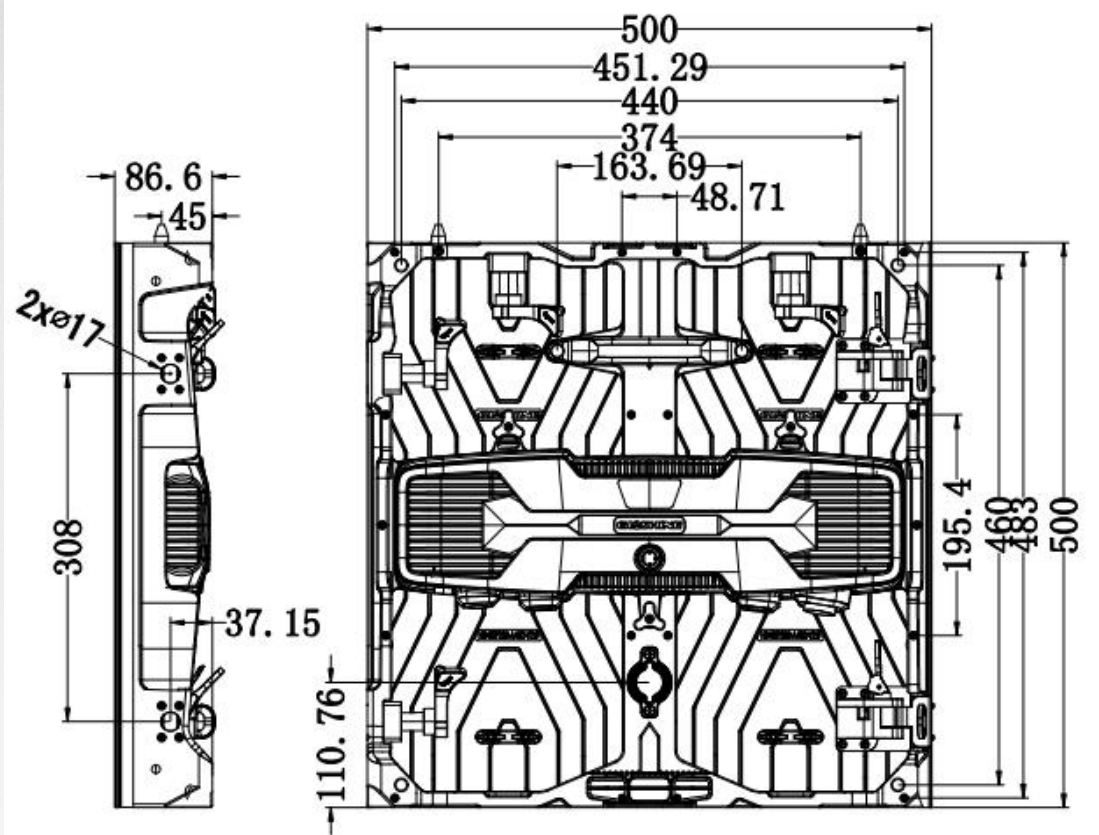

Cabinet Size(W*H*D): 500*500*87mm
Cabinet Weight: 9.50kg

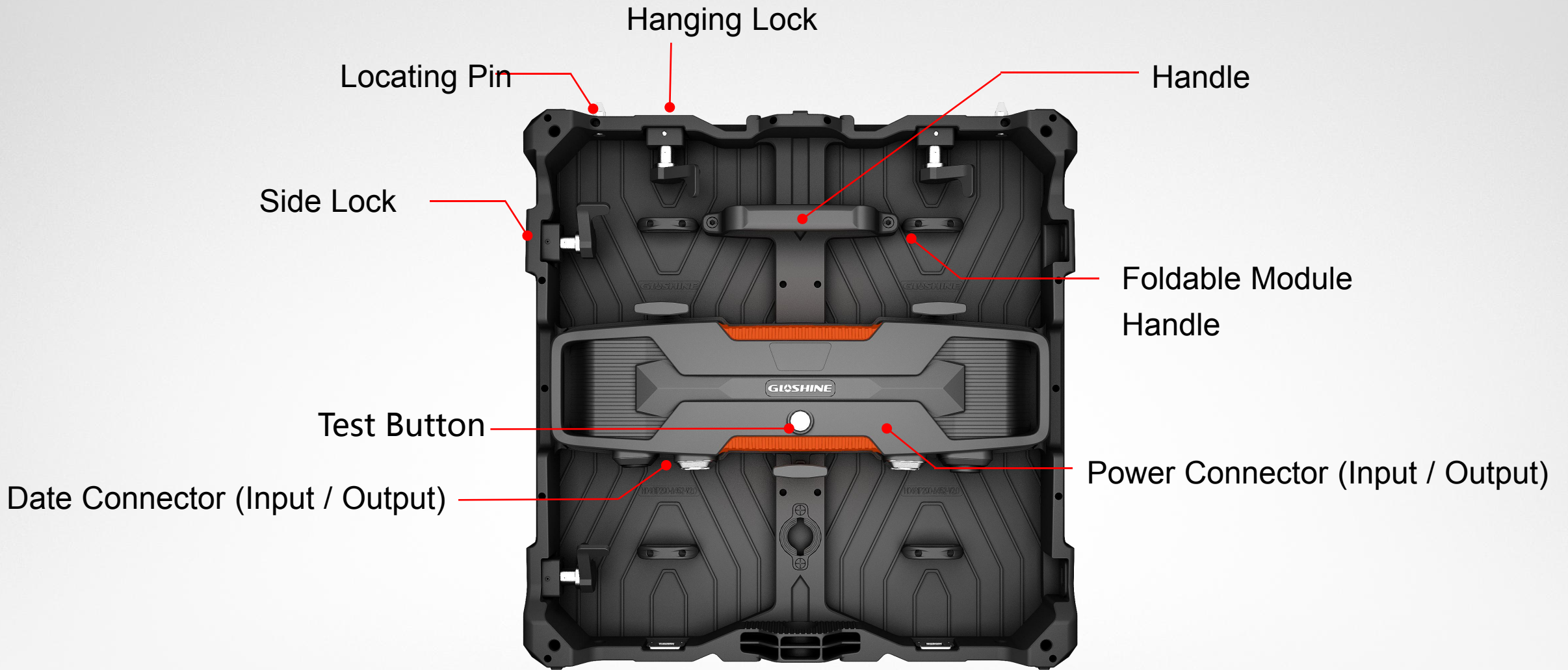

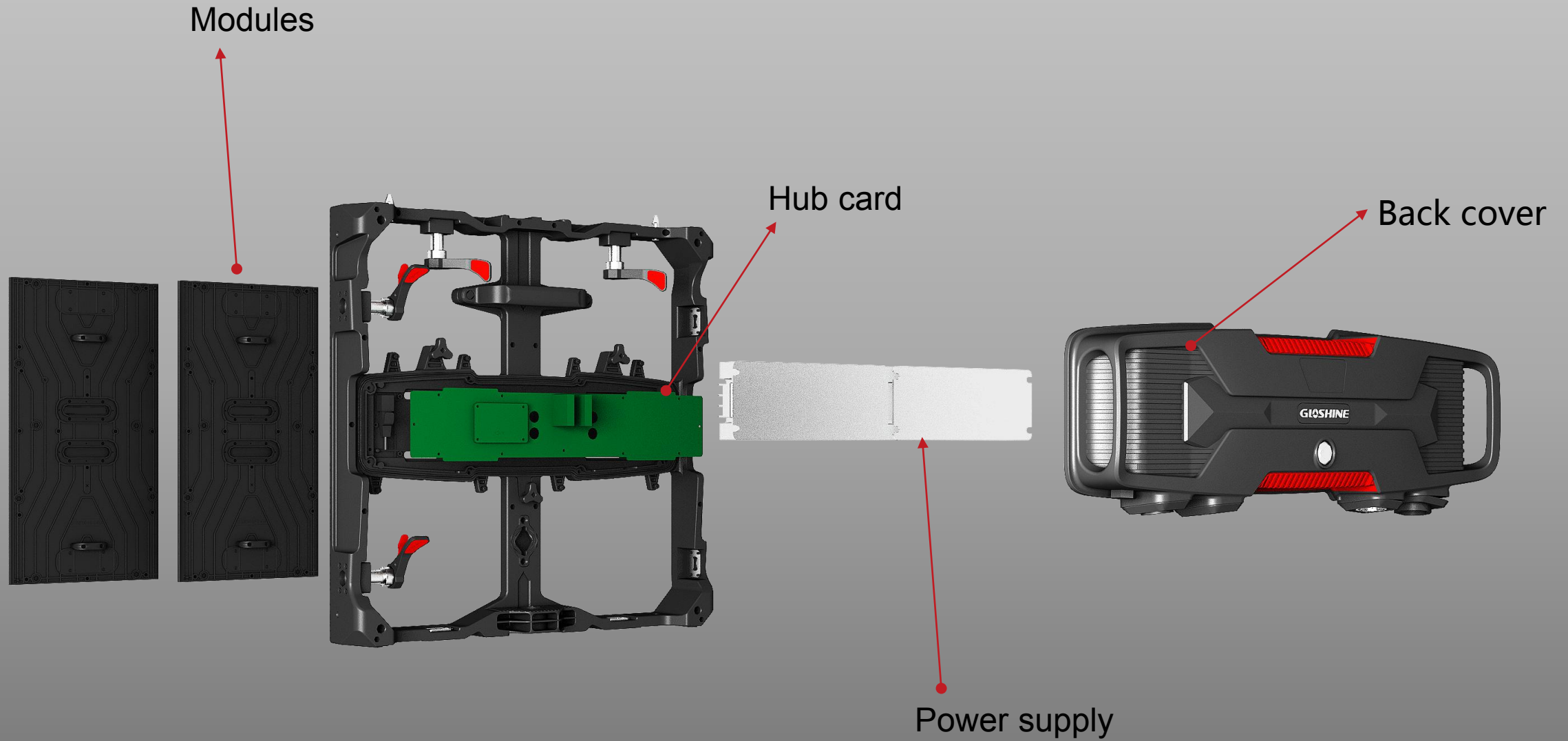

Remark: Hub card, PSU, Receiving card were integrated in back cover



Continuation of classic design

Legend series is still keeping the concise and great momentum style; it adopts modular design and also the benchmark of industrial design.

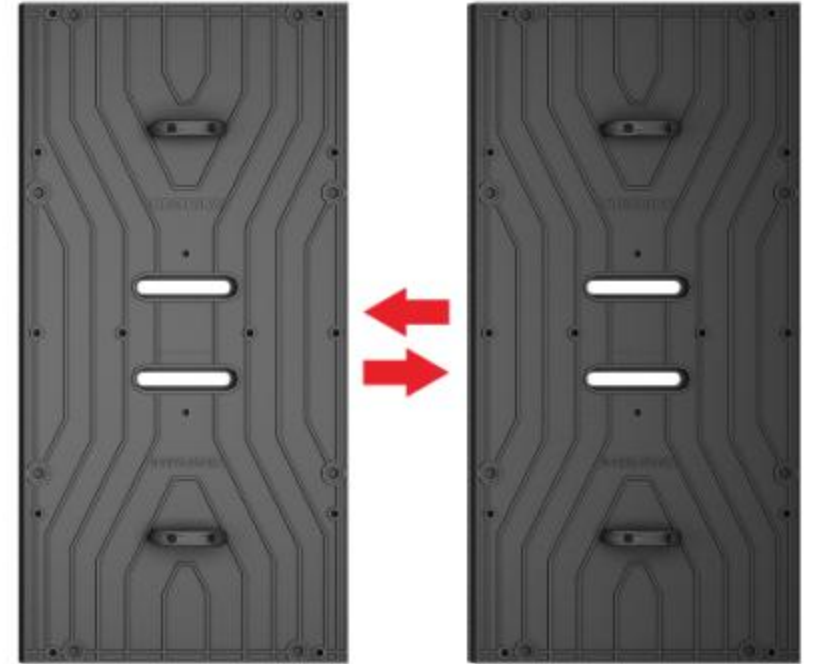
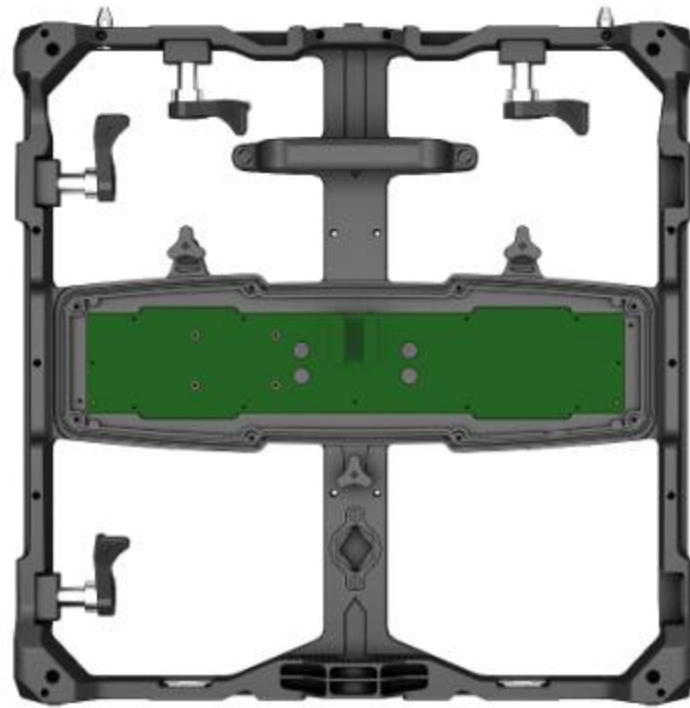

Modular design

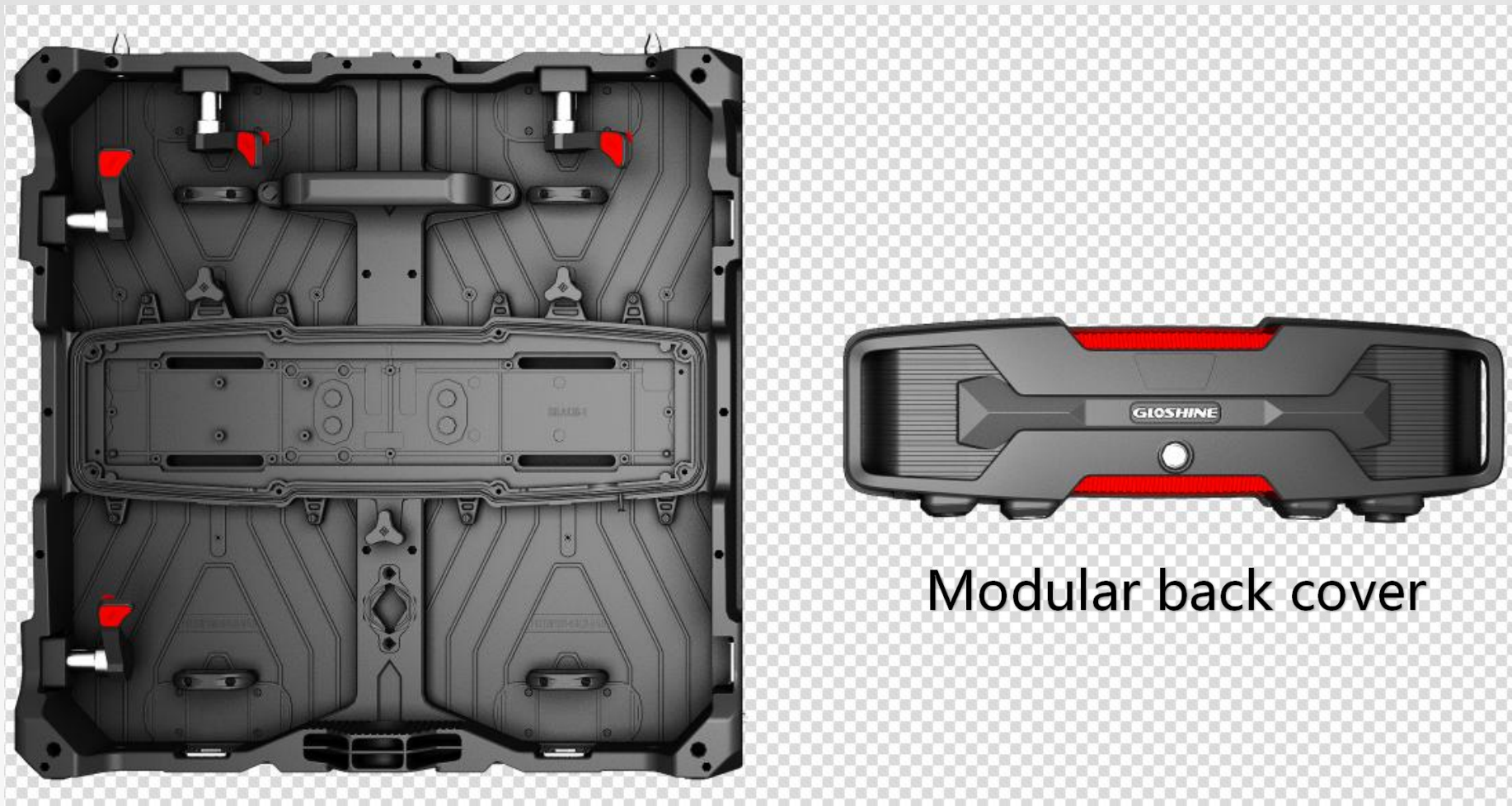

Modular back cover

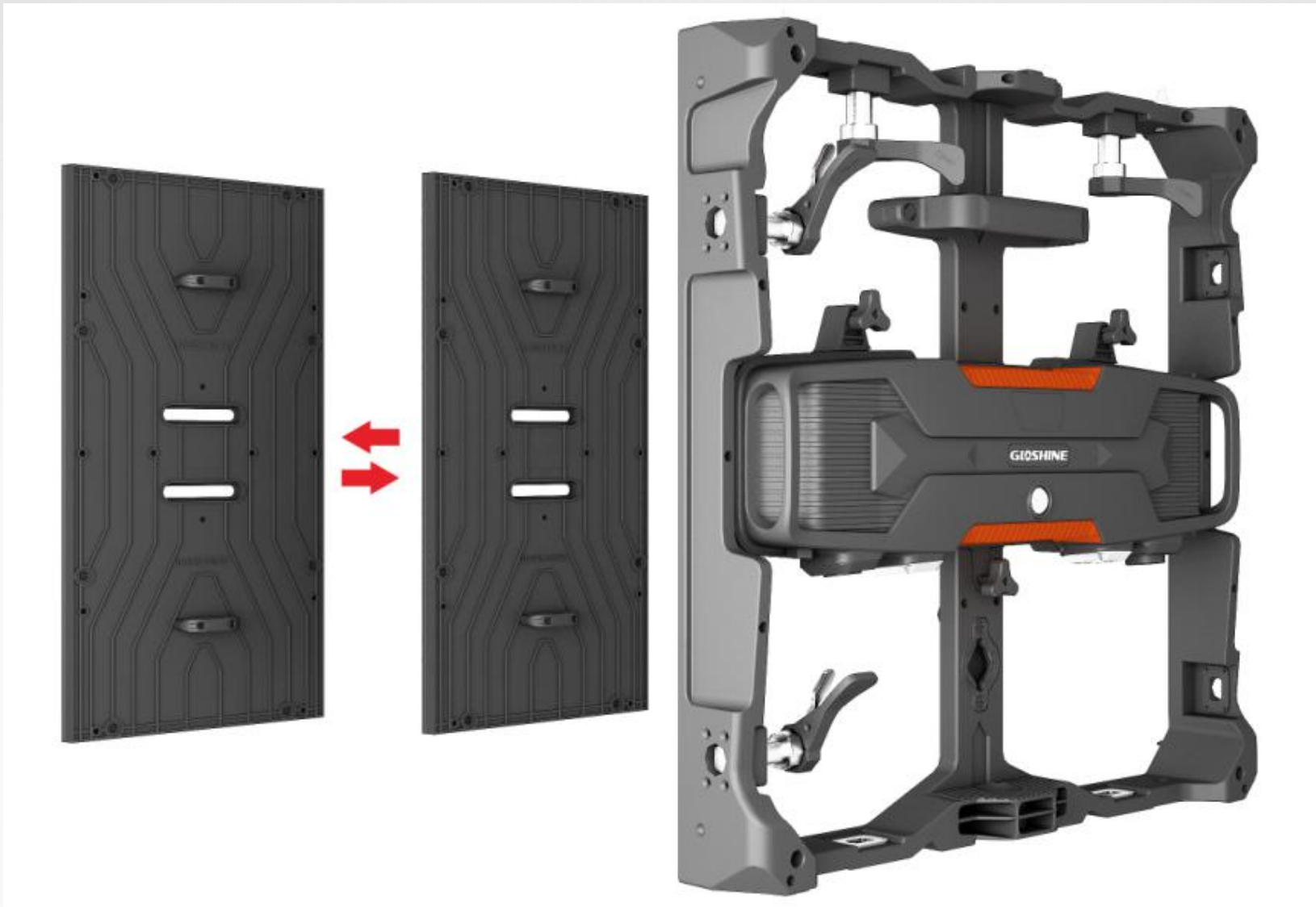

Interchangeable module

High configuration
waterproof Neutrik connector
IP rate IP65/IP54



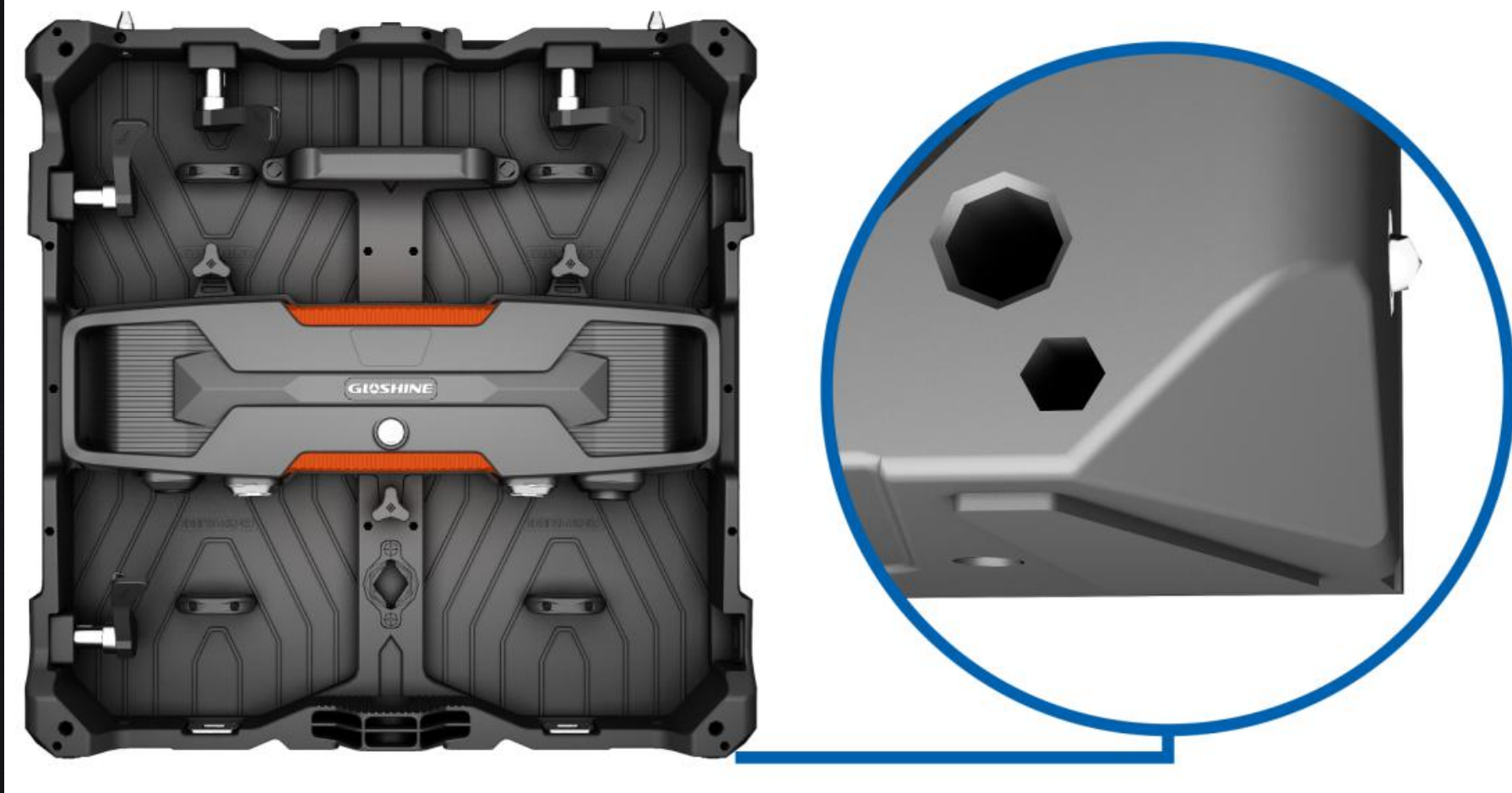

Collision prevention

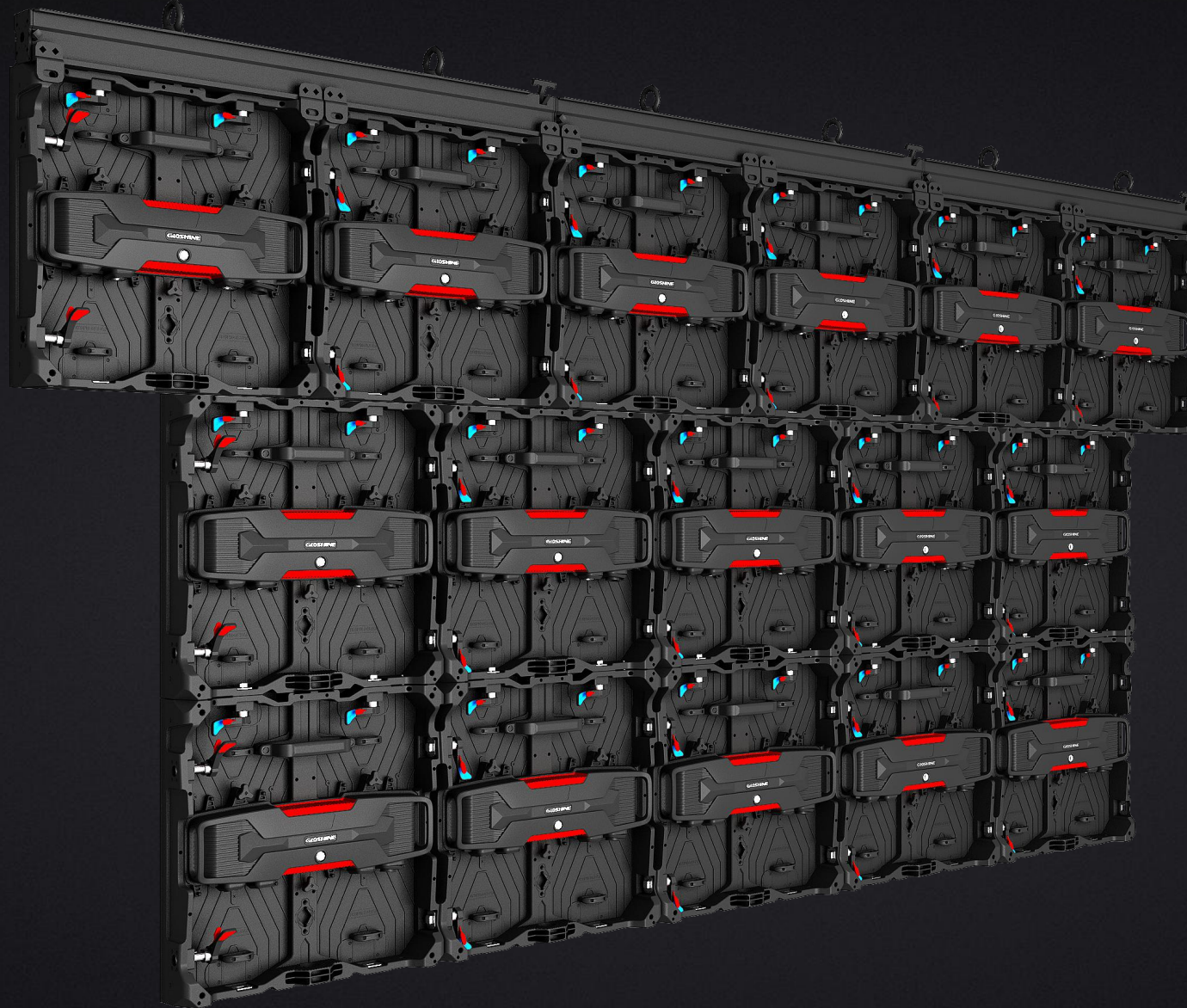

Legend series support composite installation and mixed installation.



Stacking system installation

4m height is allowed.

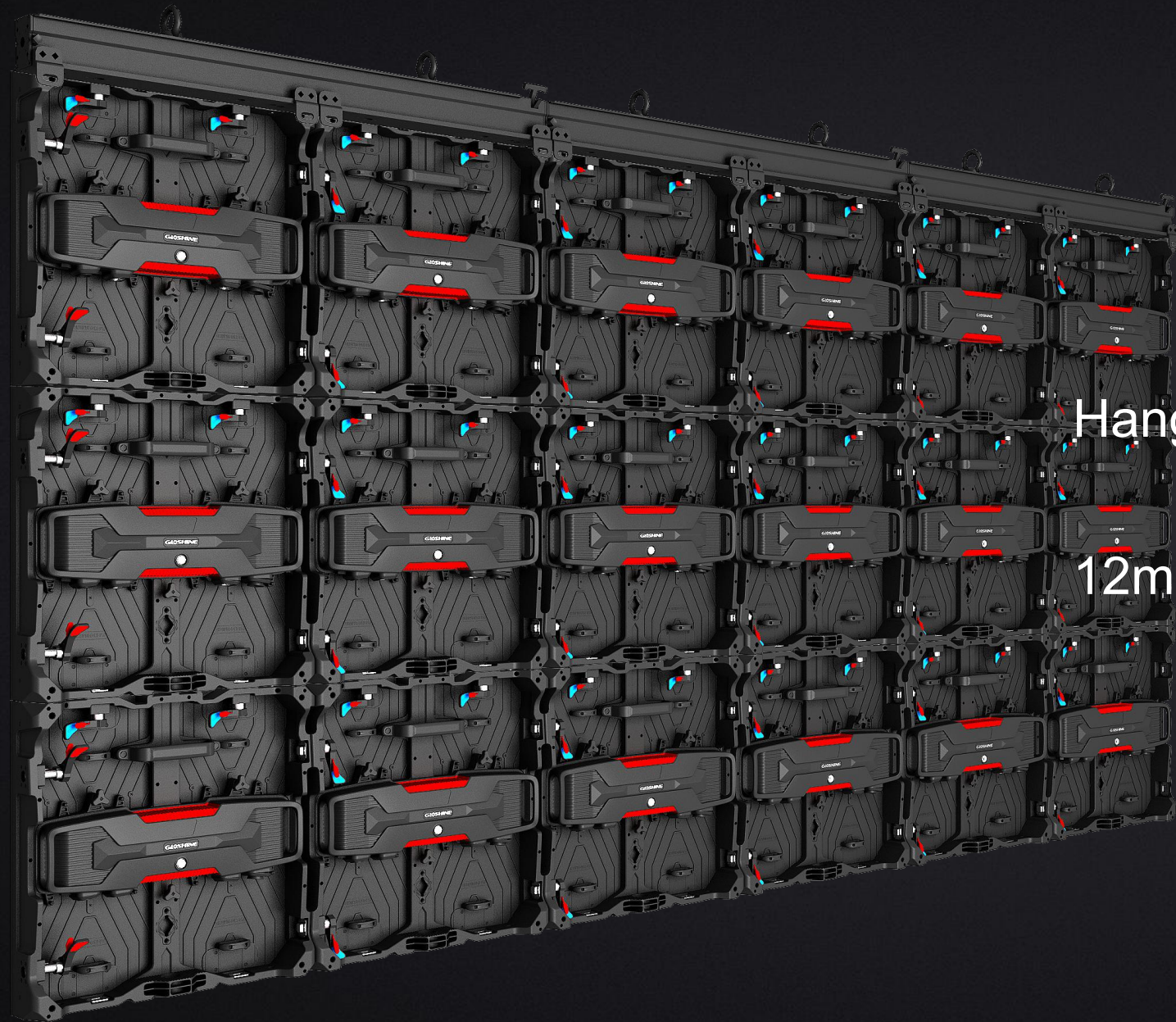

Hanging installation

12m height is acceptable.

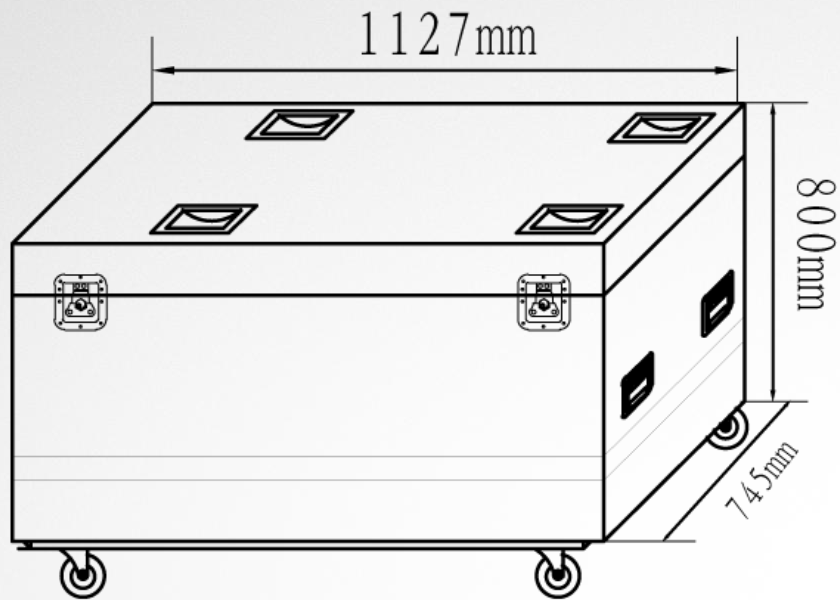

X 8Pcs

Loading: 8 pcs in 1

Eco-friendly material: E1 level of eco-friendly plywood material.

Safety and reliable: External corner ball design and crushproof .

Anti-electrostatic: Anti-static materials inside.

Strong loading: Max 400kgs load-bearing



THANKS

FOR ATTENTION
