

Caution: please read this user manual carefully before you initially start-up

LED Fresnel Spotlight User Manual

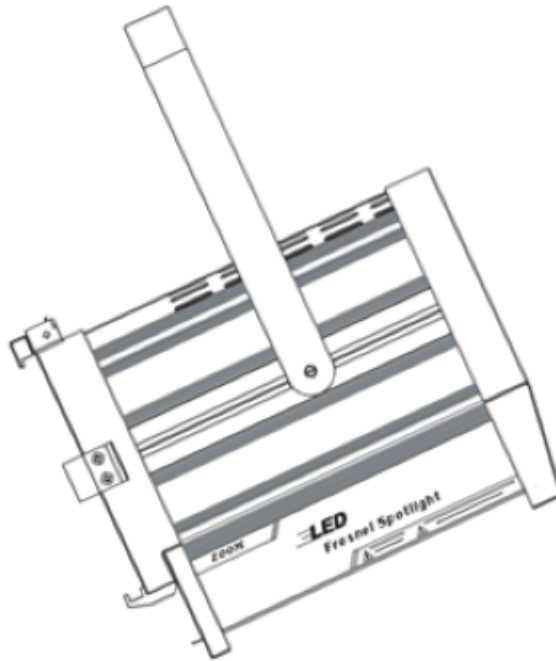

LED Fresnel Spotlight

Professional lighting equipment

Catalogue

1、	Overviews.....	4
2、	Packing list.....	4
3、	Product data.....	4
4、	Technical parameters.....	5
5、	Dimension、 Mappings & Pictures of fittings.....	6
6、	Control system description.....	10
7、	Operating instructions.....	11
8、	Safety instructions.....	12
9、	Notes for installation and operation.....	13
10、	Comparison of common faults.....	14

Guarantee card

All products sold by Ilightings are covered by 12 months warranty from the date of purchase .
During this period, we will guarantee to keep the goods in repair if a failure occurs under normal operation.

Ilightings assumes no responsibility for the following circumstance

1. Those products that have refitted by the customers;
2. The troubles resulting from customer's careless or abnormal use;
3. The improper installation and the incorrect voltage supply;
4. The damage or faulty performance caused by misuse, improper installation, careless handling or where repairs have been attempted by others.
5. The breakdown and the damage caused by the Force majeure.
6. Without guarantee card;

Ilightings provide paid service for the products which beyond the guarantee conditions .

Customer name : _____

Contact phone No. : _____

Date of purchase : _____

Product model No. : _____

Dealer : _____

Operation, Programming and Safety Manual

1、 Overviews

Thank you for purchasing our product. Before carrying out any operations with the product. Carefully read this instruction manual and keep it with care for future reference. It contains important information about the installation, usage and maintenance of the unit. Please strictly follow it.

The product conforms to the international standard DMX512 agreement. The products can be controlled in signal use and also can be controlled in many units. Sleek and stylish, precise and accurate optical system design, bring and clear light effects. All above makes our products applicable to be used within the scope of film and television, theater, live events, trade show exhibits, educational facilities, retail environments, and corporate shows, etc.

* The product is compliance with the CE Standard & ROHS Standard.

* The product belongs to Ilightings registered company. the intellectual property is exclusively reserved. We will file a lawsuit on condition that it is illegally copied and imitated.

2、 Packing list

This series of products supply standard carton packaging, flight case can be supply for your requirement.

Do not extrude the plastic parts for avoiding any breaking or deformation.

When receiving the product, please carefully check whether there is any damage caused by the transportation. Check whether the following fittings are attached:

Manual/Certificate

If you need other fittings, please list them in your order.

3、 Product data

Product name : 200w LED Fresnel Spot light

Product features

- 1) Made by ABS material and aluminum profile which makes the lamp more lighter
- 2) More smooth light
- 3) Good performance of cooling system with the Ultra-quiet fan ensure the usage in the strict noise-control environment

-
- 4) Convenient design for in and out ensure the convenient linking and installation
 - 5) Much smoother dimming curve than the competitors
 - 6) Efficient cooperation between the control system and the power-supply system ensure to avoid the current noise.

Scope of application

The surface light of stage and television, video conference system, film, etc.

Product description

The sleek and stylish shell of the lamp is made by the aluminum sections. The LED light source is imported from the United States. The advanced heat-pipe conduction technology and the active cooling mode effectively protect the service life and the safety of LED.

The function and performance of it is close to the traditional competitors. It can directly replace existing Fresnel lens lamp. This LED lamp has truly realized the performance of Fresnel lens lamp for it can continuous focusing, and the light is smooth no matter the beam angle is spot light or floodlight. The light from Fresnel lens lamp, cooperating with the digital cameras of radio, television and film industry, can adjust to the optimal color, and make the skin color more soft and vivid.

Focusing properties: the characteristic of traditional Fresnel lens lamp is its multiple functions; especially it can adjust from spot light to floodlight according to the need.

No matter the large range lighting for taking dolly shot, or the accumulation point light for high lighting shot, the lamp with continuous focusing function can be consistent with all shooting demands.

The controlled and adjusted beam: precisely control the beam to make the actors stand out from the background, effective lighting device can avoid the overflow effect of astigmatism. It is an important part of lighting that it can be controlled and adjusted. LED spotlight inherits the advantages of traditional Fresnel lens lamp. It effectively controls the beam by the light barrier and the screw. The only difference is the beam temperature of LED spotlight is extremely low, which not only to create a comfortable working environment for the actor, but also greatly reduces the energy consumption of the air conditioner of the studio.

4、 Technical parameters

Power supply : AC90V-120V/200V-250V , 50Hz/60Hz

Light source : Citizen 180w COB LED (one)

Power : 200W

Optical lens : 150mm Fresnel Optical Lens

Adjustable Color Temperature:3200K 、 5700K
Color Temperature deviation: $\pm 5\%$
Life : 50000h
Color rendering index: CRI 85 Ra
Manual Dimmer : 0%~100%
Beam angle: 12° ~55°
Control system : 16 Bit dimming,STM32 control chip, DMX512
Power Connection: Swiss Neutrik Power Con
Max Clock frequency : 72m/Hz
Dimming Frequency : 8k/Hz
Channels : 1CH
Display screen : LCD
Working Environment : $-20^{\circ}\text{C} \sim 35^{\circ}\text{C}$
Tilt : $\pm 90^{\circ}$
Protection class : IP23
Light barrier : Four-leaf(supply for requirement)
Weight : 5KG

5、 Dimension、 Mappings & Pictures of fittings

Dimension : 360x270x395MM

Hanging installation: screw holes can be installed 13MM

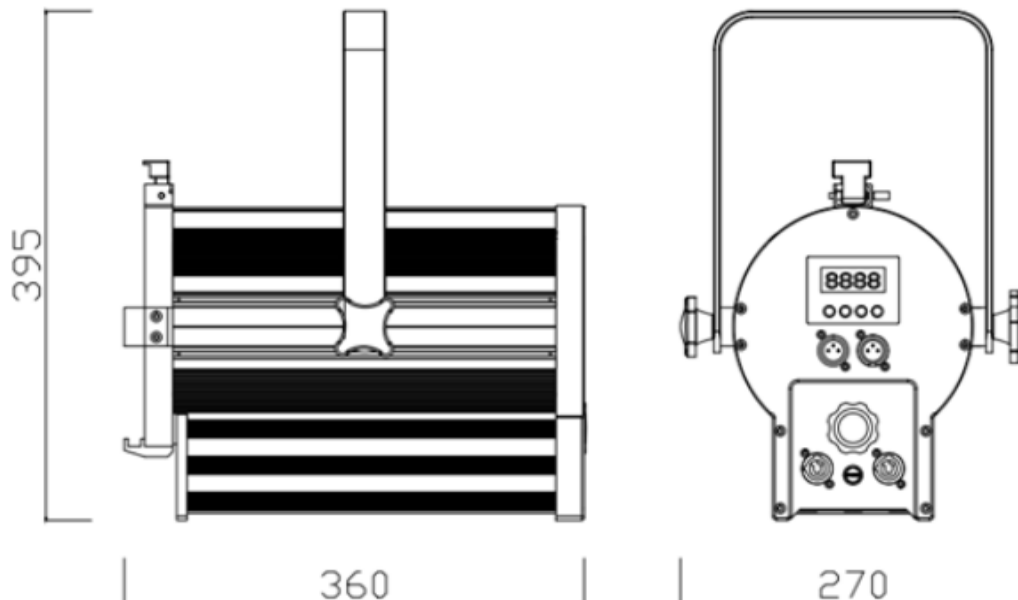

Photographic chart

Citizen light source, color temperature :3200K, CRI:85 Ra

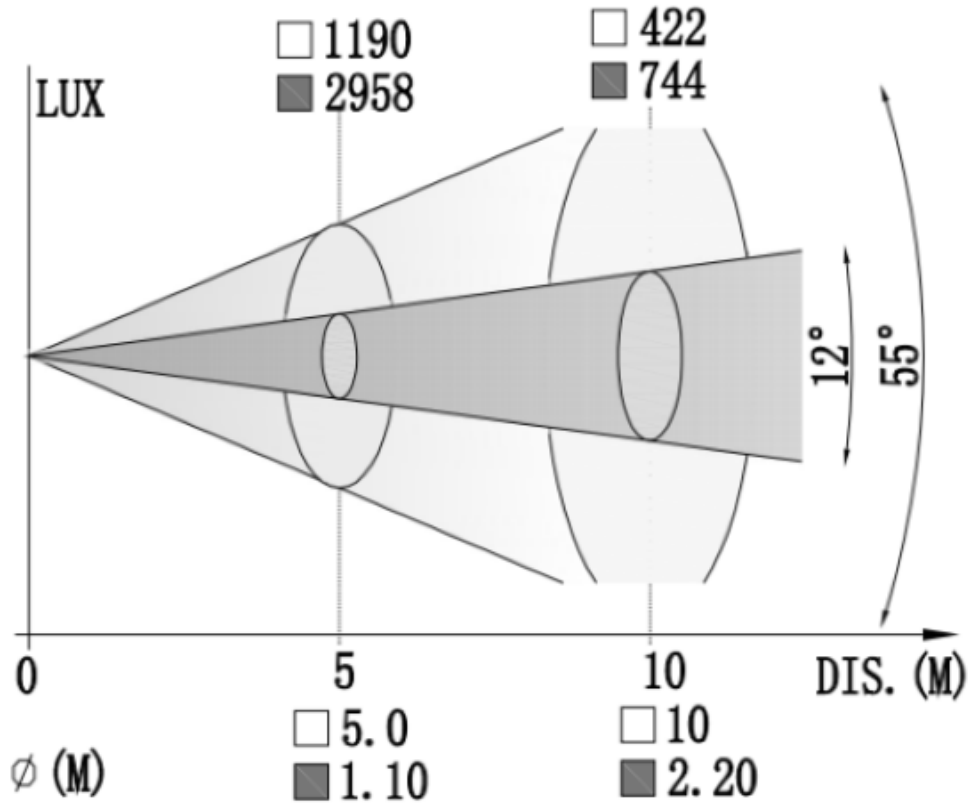

Philips light source, color temperature :3200K, CRI:95

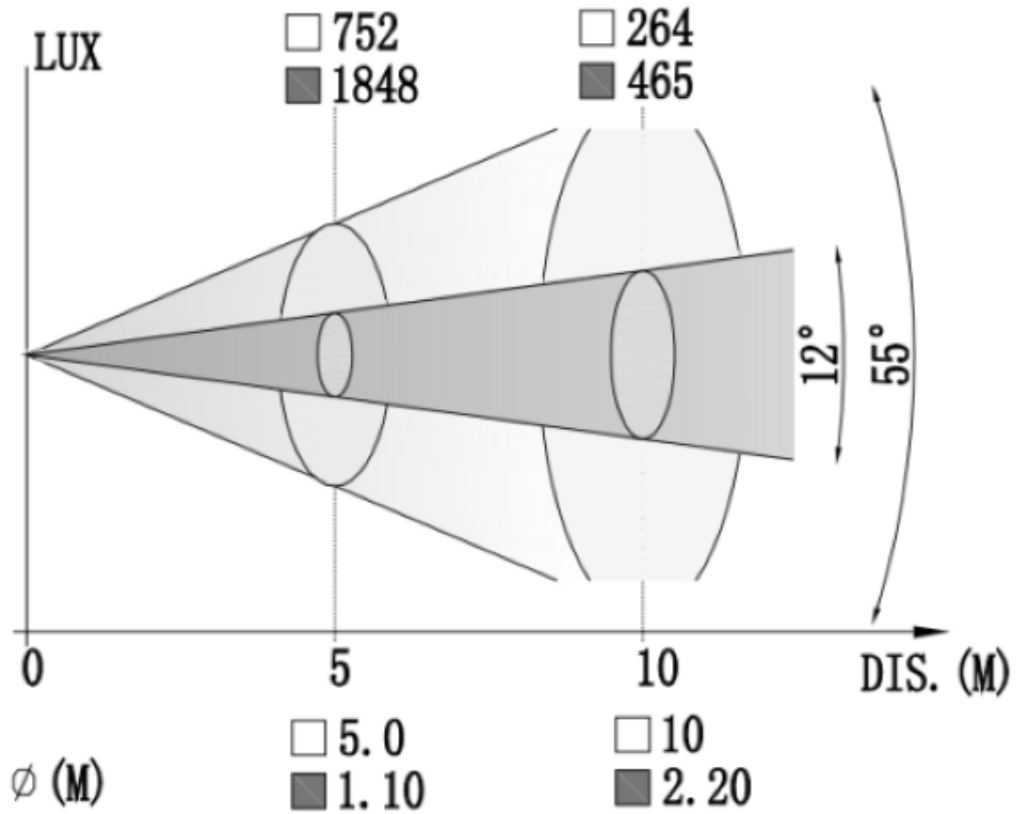

Fittings

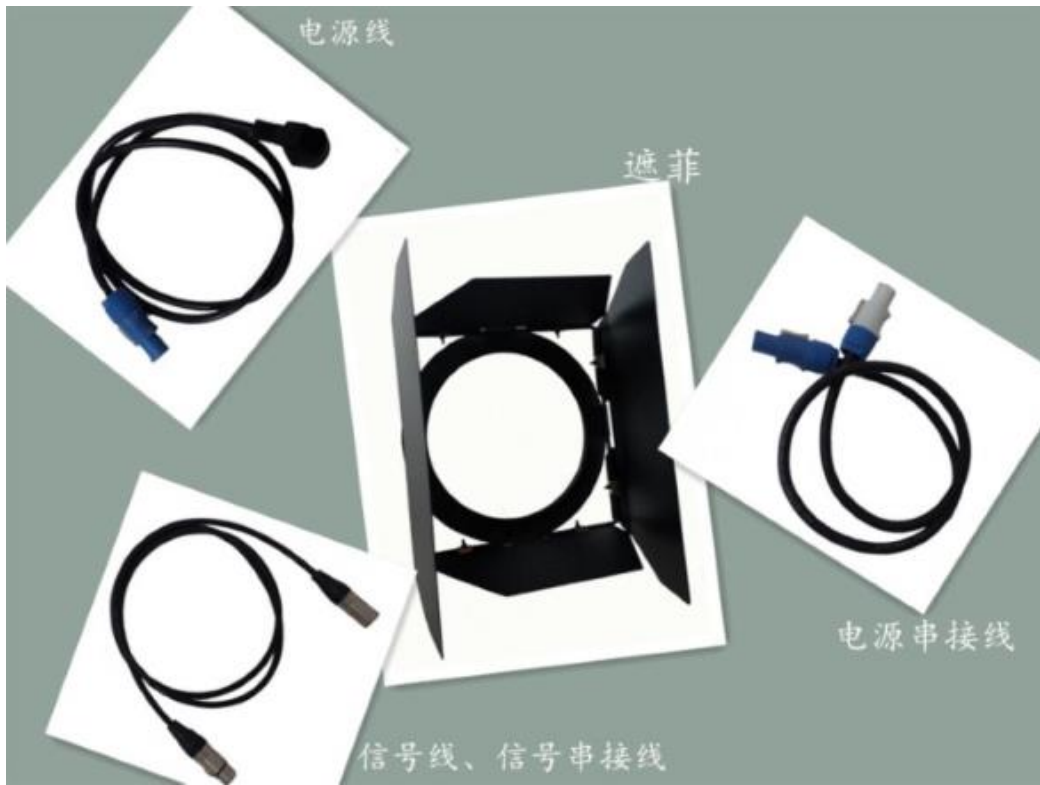

Connection of the power line



Connection of the power line



Moving yoke (Rail-type yoke with adjustable barycenter and angel)



Focusing fitting



Mounting bolt hole ($\Phi 13\text{MM}$)

Four-leaf Light barrier



6、 Control system description

Lamp power supply & connection of signal line

1、Connection and control of the lamp power source

The product uses 1.5 SQMM copper core cables to be the input line for power supply. When connecting the power line, the maximum of connecting lamps is 12 under voltage 220V; and the maximum of connecting lamps is 6 under voltage 110V.

When using the DMX console, the length of wire between console and the lamp, and the length of wire between the lamps should not be longer than 60 meters. There must be signal amplifier when the length of wire is longer than 60 meters.

2、Connection of the lamp signal line

This LED lamp receive digital signal in DMX512 (1900) format. It can work in either the master or slaver mode under EDIT and self-propelled mode. The master-slave mode also connects by DMX line. Using the cylindrical 3 core XLP cable provided by the manufacturer, connect the XLR-XLR control line from the DMX controller output port to the DMX input port of 1st lamp, then from the DMX output port of 1st lamp to the DMX input port of 2nd lamp, etc. Until all the lamps are connected in a chain. Finally insert the loop into the DMX input port of last lamp for complete the connection.

Diagram of signal connection

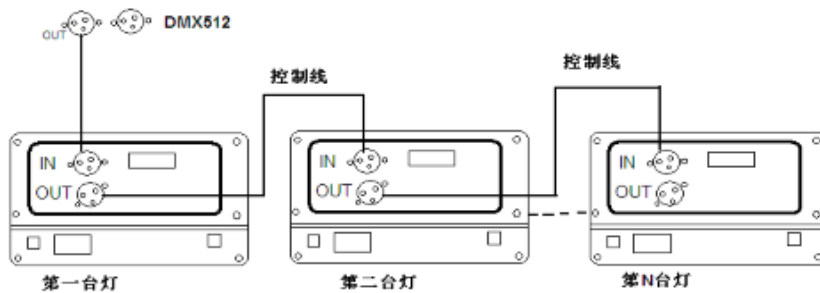

7、 Operating instructions

Menu instruction

Display screen

DMX Address SET :Press DMX

Address UP、DMX Address DOWN for modify the DMX address



DIMMER SET :Press DIMMER UP、DIMMER DOWN for manual dimmer, illuminance Value: 0-255

DMX512 Channel table

Channel	Value	Control function
CH1	000	Illuminance 0%

	000-255	Illuminance 100%

The characteristic of control system:

16 Bit dimming level: Comparing to the 8 Bit dimming, the changing of the light is more soft and delicate. The precision stabilizing control chip STM32; the international signal protocol DMX512.

Maximum clock frequency : 72m/Hz ;

Output frequency : 8k/Hz ;

Function instruction :

Version number of the program will be shown when power on and then the system will enter the running mode saved before last power off in 1 second.

Running mode: DMX mode and Manual dimming

- DMX mode: Enter this mode with DMX Address SET interface. In this mode, the lamp receives the signal from the DMX console or the Master; when there is no DMX signal, the system will receive the synchronous control by the Master as its slave.
- Manual dimming: Enter this mode with Dimmer SET interface. In this mode, when there are slaves associated with the bus, the system will synchronous control the slaves as the Master.

After modifying the DMX address, DIMMER value and operation mode, the system will automatically save these parameters in 3 seconds. The saved parameters will not be lost when power off.

Master-slave model

Connect the control line from the DMX output port of 1st lamp to the DMX input port of 2nd lamp, then from the DMX output port of 2nd lamp to the DMX input port of 3rd lamp, etc. Until all the lamps are connected in a chain. Finally insert the loop into the DMX input port of last lamp for complete the connection. Choose the 1st lamp to function as the master, and run it in the Self-propelled Mode or EDIT mode; other lamps will work as slaves with the same effect, and run them in the Slave Mode or Address code Mode. Note: the DMX input port should not input the DMX512 signal

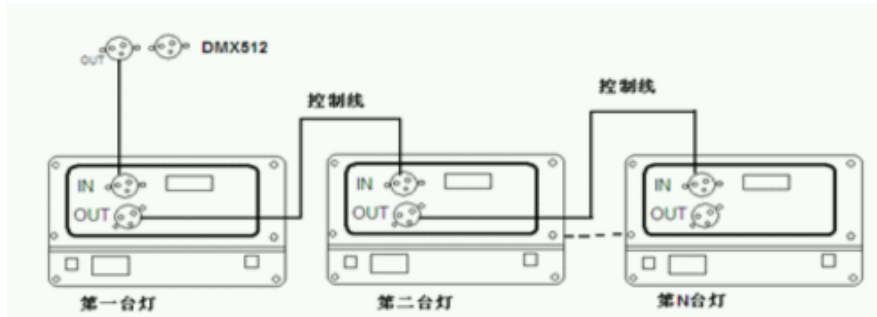

8、 Safety instructions

1. Maintenance :

The lamp has been passed strict examination before leaving the factory. In order to ensure the normal and safe operation, user must follow the instructions of this manual ;

Ilightings assumes no responsibility for those products that have refitted by the customers ,and the troubles resulting from customer's careless or abnormal use;

Keep the lamp work under the required voltage, ensure the use of voltage is in the voltage range of technical parameters ;

For using the power line input and output connector, the maximum of lamps is 12 under the voltage 220V; the maximum of lamps is 6 under the voltage 110V. The number of lamps for using the DMX512 input and output signal line is not limited;

Do not install the lights near the heat source to avoid the rising of lamp temperature and affecting the normal use of lamps and lanterns, even damaging the lamp;

Check before use the connection of 110V~220V AC power to ensure that the connection between power supply and switch is good. Please use qualified power plug and outlet;

During move and installation, make sure the device not crashed with metal parts and other tough materials.

2. Warning :

Unqualified person involved with installation, operation and maintenance of this lamp is prohibited

Don't insert other things into the inside of the lamp, so as to avoid anything reaching the part with high voltage, then lead to partial short circuit, or else a fire or electric shock may occur, and then affect the normal use of the product.

Please keep the bulb clean, do not directly touch the bulb glass by hand.

Do not watch the light source straightly for avoid the damage to the eyes.

9、 Notes for installation and operation

1. Installation

(1) Before the location and installation of the lamp, ensure the stability of its installation point, which can hold at least 10 times the weight of the lamp.

(2) Installation method: use one piece of professional clamp , M13 bolts, and our own retaining screw to install; pull the safety chain(distribution or owned) through the yoke or other hanging objects and tighten the fixation screw. Check if there is any wear of the safety chain and loosen of the clamp periodically. In addition, cut off the power supply when remove the lamps to ensure safety. Take the safety rope first, then remove the hanging, and pay attention to the safety of pedestrians below.

2. Notes:

(1) Do not frequently switch the lamp, so as not to affect the service life of the bulb. Try to avoid the lamp to run for long periods of time.

(2) All screws used for installing the lamp and any of its parts should be tightly fastened to avoid the strong jarring or pounding. Don' t use the lamp in a jittering situation.



10、 Comparison of common faults

Comparison of common faults	
Problems	Reason and resolution
Lamp not work	1、 Check if the power line is connected 2、 Check if the lamp work under the required voltage

Lamp work, not control by the controller	<p>1、Check if the DIP starting address code setting is correct</p> <p>2、 Check if the XLR signal line is destroyed</p>
Master-slave Mode, the master work, but the slave not work	<p>1、 Confirm there is only one master connected without the DMX console ; others are in the slaver or address code mode</p> <p>2、The Master-Slave Mode has some problems. Check for the connected line</p>
Keys not work	Check if any of the keys does not reset
Low light intensity, brightness decrease obviously	<p>1、 Check if the LED light source at the end of their life span</p> <p>2、Make sure the internal and external of the optical system is clean</p>
Beam impure (with halo)	Clean the bulk and lens from impurities caused by dust and oil